

Ausführung / Variant

- Mit innenliegender Welle
- Mit druckdichtendem Deckel

- With inside shaft
- With pressure sealed cover

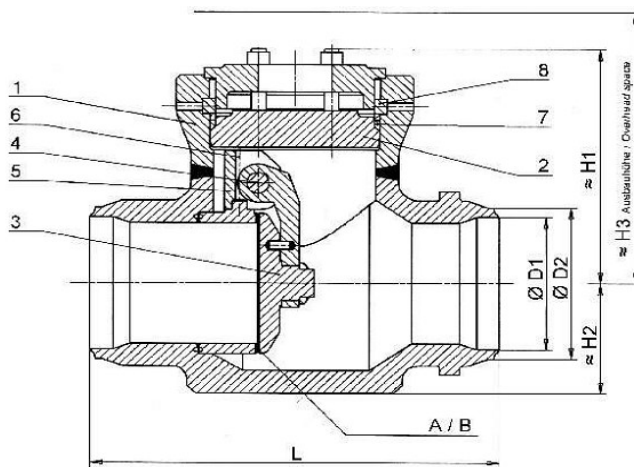

Abweichungen von der bildlichen Darstellung sowie Maß- und Werkstoffänderungen sind möglich.

Drawing, dimensions and material are subject to change.

Werkstoffe / Materials

Pos.-Nr. Item No.	Bauteil Component	Werkstoff/Stoff-Nr. Material / Material No.		
1	Gehäuse Body	A105	A182-F11	A182-F22
A	Sitzdichtung Body seat surface	17% Cr		
2	Deckel Bonnet	A105	A182-F11	A182-F22
3	Platte Disk	A105	A182-F11	A182-F22
B	Plattendichtung Wedge seat surface	17% Cr		
4	Welle Shaft	17% Cr		
5	Lagerbock Pillow block	Stahl / Steel		
6	Zylinderschrauben Screws	CrNi		
*	Deckeldichtung Gasket	Reingraphit / Pure graphite		
8	Segmentring Thrust	A105	A182-F11	A182-F22

* Empfohlene Ersatzteile Weitere Werkstoffe auf Anfrage
Recommended spare parts Further materials on request

Abmessungen und Massen / Dimensions and weights

Schweißfugen ANSI-B16.25
Welding grooves ANSI-B16.25

Class	DN	Size	L		H1		D1 min		D2 max		Masse / Weight	
			mm	inch	mm	inch	mm	inch	mm	inch	kg	lb
2500	80	3"	368	14,5	240	9,4	52	2,05	115	4,53	90	198
	100	4"	457	18,0	280	11,0	66	2,60	145	5,71	155	342
	125	5"	533	21,0	375	14,8	83	3,27	180	7,09	275	606
	150	6"	610	24,0	460	18,1	100	3,94	220	8,66	395	871
	200	8"	762	30,0	525	20,7	132	5,20	275	10,83	735	1620
	250	10"	914	36,0	590	23,2	166	6,54	325	12,80	1210	2668
	300	12"	1041	41,0	715	28,2	198	7,80	410	16,14	1450	3197
	350	14"	1118	44,0	825	32,5	218	8,58	460	18,11	1695	3737
	400	16"	1245	49	890	35	249	9,8	510	20,08	2200	4850

Alle Abmessungen in mm / All dimensions in mm